

Regulations of reference

NTC 2008 DM 14/01/2008

Components

The columns (A1 and A2) provide support; the lower cast iron column (A2) has an octagonal base and is inserted in the upper hot-dip galvanised steel column (A1) with an aluminium base, topped with an aluminium capital.

The base panel is composed of a plinth (B) and a windowsill (C), both in cast iron, interconnected by a hot-dip galvanised steel sheet (D), internally reinforced and finished with a 20mm [3/4"]-thick insulated sandwich panel.

The window frames (E) are made of aluminium, opened upwards, with laminated glass (thickness: 6/7mm [1/4"]).

The two doors, made of aluminium profiles, can be opened outwards with a door width of 900mm [35 2/4"] and are equipped with a closing spring.

The shutters (F) are roller shutters and made of fully insulated steel, complete with external locks; the shutters are operated manually but assisted by a spring system that reduces their weight.

The roller shutters (G) are covered internally by a white wooden box (H) equipped with a door that can be opened for maintenance purposes and, outside, by hot-dip galvanised steel strip (I).

The cover is made from hot-dip galvanised steel beams (M) that support a copper-coloured fibreglass cover (N) and an internal false ceiling made from wooden matchboarding (O) (insulated with a 12mm [2/4"]-thick layer of expanded polyethylene and 30mm [1 1/4"]-thick expanded polystyrene panel). A sheet (L) of hot-dip galvanised steel is placed on the projection of the cantilever roof.

The cantilever roof is supported by steel beams and brackets (P).

The gutter (Q) is made of an appropriately-shaped hot-dip galvanised steel sheet, with copper outriggers, visibly covered by a decorated steel fascia (R).

The skylight is made from hot-dip galvanised steel beams that support a copper-plated fibreglass cover and an internal false ceiling (insulated with a 12mm [2/4"]-thick layer of expanded polyethylene and 30mm [1 1/4"]-thick expanded polystyrene panel) in wooden matchboarding. The roof, like the cantilever roof, is equipped with a gutter with the same features.

The windows (alternately fixed, with a lift-up opening) are made from a hot-dip galvanised steel frame, complete with glass.

The two decorative tops (S) is made of aluminium.

The kiosk is supplied with three central globe lights (diameter: 350mm [13 3/4"]) in opal white PMMA, with a bulb holder.

KIOSKS

ARTICLE: 3166.002.610

TECHNICAL DESCRIPTION

Materials

The standard colours are:

- Cast iron UNI EN 1561
- FE 360 steel UNI EN 10219-1

See the specific descriptions on the painting cycles of the materials that make up the product.

Finishes

The standard colours are:

- Neri Grey
- Green RAL 6005

Other colours are available upon request.

Weight

Standard indications

Installation

To place in operation, it is necessary to prepare a perfectly level brickwork base, measuring approximately 100mm [4"] high from the ground.

The electronic, hydraulic and flooring systems are not included.

Energy class

The energy class of the kiosks is assessed from time to time based on the place of installation, the regulations in force and the customer's specific requirements.

Warranty

Standard

Simplified kiosk

Octagonal plan

Double hipped roof

Increased height

3166

Kiosk plan

002

Roof type

610

Column height

Octagonal plan

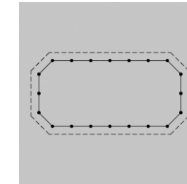

Usable area

58m² [624 sq ft]

Covered area

79.4m² [855 sq ft]

Modules

20

Double hipped roof

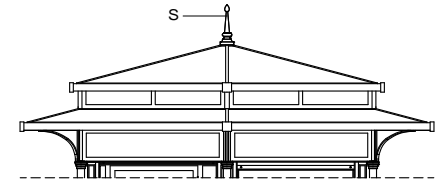

Increased height

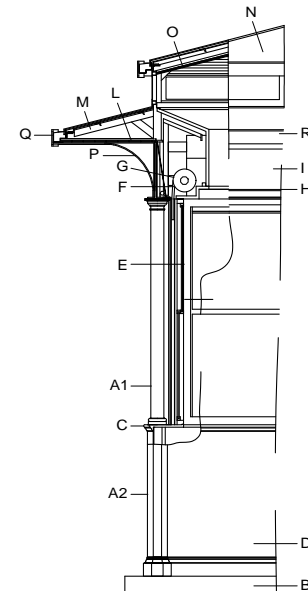

KIOSKS
ARTICLE: 3166.002.610
PLAN
SCALE 1:100

Simplified kiosk
Octagonal plan
Double hipped roof
Increased height

3166

Kiosk plan

002

Roof type

610

Column height

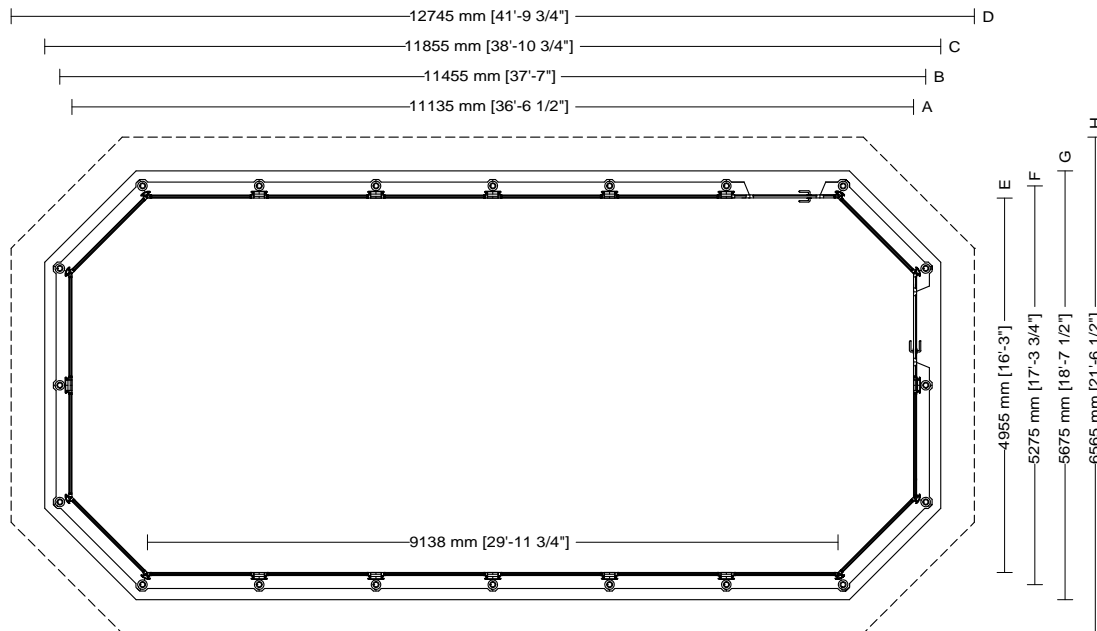

Usable area

58m² [624 sq ft]

Covered area

79.4m² [855 sq ft]

Modules

20

Drawing key

- A Internal windowsill
- B Column axis
- C Foundation base
- D Roofing
- E Internal windowsill
- F Column axis
- G Foundation base
- H Roofing

KIOSKS
ARTICLE: 3166.002.610
ELEVATION
SCALE 1:100

Simplified kiosk
Octagonal plan
Double hipped roof
Increased height

3166

Kiosk plan

002

Roof type

610

Column height

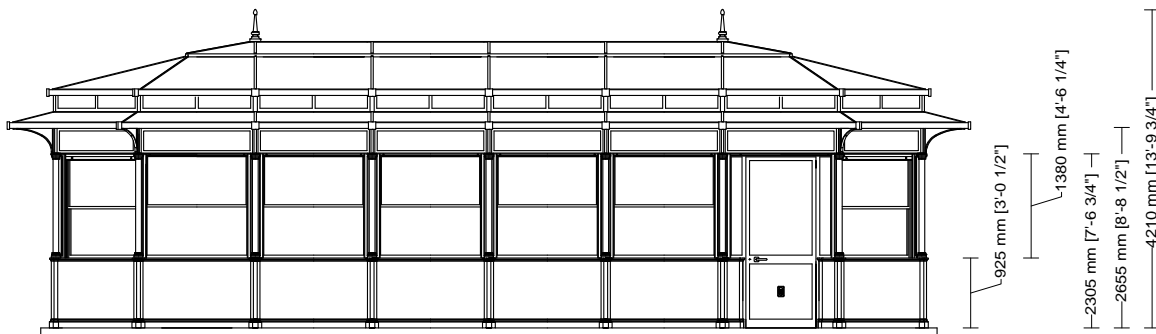

KIOSKS
ARTICLE: 3166.002.610
SECTION
SCALE 1:100

Simplified kiosk
Octagonal plan
Double hipped roof
Increased height

3166	002	610
Kiosk plan	Roof type	Column height

