

NERI



Punta della Dogana or Punta della Salute is an area of Venice. It is a thin triangular tip dividing Canal Grande and Canale della Giudecca, overlooking the San Marco Basin. The area is home to three important architectural complexes: the Basilica of Santa Maria della Salute, the Patriarchal Seminary and the Dogana da Mar complex, which is where the area gets its name.

Punta della Dogana, o Punta della Salute, è un luogo famoso di Venezia; una sottile punta triangolare di divisione tra il Canal Grande e il Canale della Giudecca, prospiciente il Bacino San Marco. La zona ospita tre importanti complessi architettonici: la Basilica di Santa Maria della Salute, il Seminario Patriarcale e il complesso della Dogana da Mar, da cui l'area prende il nome.







The Seventeenth century building, by Benoni, has a triangular floor plan, made up of 8 spans developing over two floors, and it is crowned by a tower holding up the Palla d'Oro, a gilded bronze sphere supported by two atlases, portraying the world supporting the so-called 'Occasio' statue. This statue represents Fortuna and it turns to indicate the direction or the wind and, symbolically, the changeability of fortune itself. At the time of the Republic of Venice the complex was used as the customs headquarters for cargo and goods subject to naval trade.

L'edificio seicentesco, opera del Benoni, è a pianta triangolare, costituito da 8 campate sviluppate su due piani ed è coronato da una torre sovrastata dalla Palla d'Oro, sfera in bronzo dorato sostenuta da due atlanti, a raffigurare il mondo su cui poggia la statua detta "Occasio". Tale statua rappresenta la Fortuna: è rotante e indica la direzione del vento e, simbolicamente, anche la mutevolezza della fortuna stessa. Ai tempi della Repubblica di Venezia il complesso, per la sua posizione centrale, veniva utilizzato come sede doganale per le merci e i beni oggetto del commercio navale.





Lamp post Restoration

Positioned right on the tip of Punta della Dogana for more than 150 years, there is a great post made by Hasselquis of Venice between 1851 and 1859, presumably the only one of its kind. Its function was that of a lighthouse: 6 metres and 50 centimetres high, with a 180 cm lamp, it is clearly visible in the misty lagoon.

Proprio sulla Punta della Dogana, oltre 150 anni, fu collocato un grande palo fuso dalla fonderia Hasselquis di Venezia fra il 1851 e il 1859, presumibilmente in un unico esemplare. La sua funzione era quella di fungere da vero e proprio faro: alto 6 metri e 50 cm. con una lanterna di 180 cm. ben visibile nella nebbiosa laguna.



Venezia

Dogana - Chiesa della Salute



The post, which weighs 1650 Kg, was restored at Neri's laboratory and equipped with a steel core to reinforce the structure and its resistance.

Il palo, che pesa 1650 kg, è stato restaurato presso i laboratori Neri e dotato di un'anima di acciaio interna per assicurarne la struttura e la resistenza.













NERI



Venice (Italy) | Punta della Dogana | Lamp post restoration

The lamp, weighing 85 Kg, is an element of rare elegance that manages to give a feeling of lightness in spite of its unusual dimensions.

La lanterna, del peso di 85 kg, è elemento di rara eleganza che nonostante le insolite dimensioni trasmette un senso di leggerezza.



We searched for the best lighting solution. We opted for a 70 W, 3000 °K central light. Power was limited so as to prevent glare, together with a 150 W lamp with lens, located in the upper cap.

In Neri è stata studiata la soluzione ottimale per illuminarla. Si è optato per una luce centrale da 70 W a 3000 gradi K, una potenza limitata per non creare abbagliamento, abbinata ad una lampada da 150 W con ottica alloggiata nel cappello superiore.

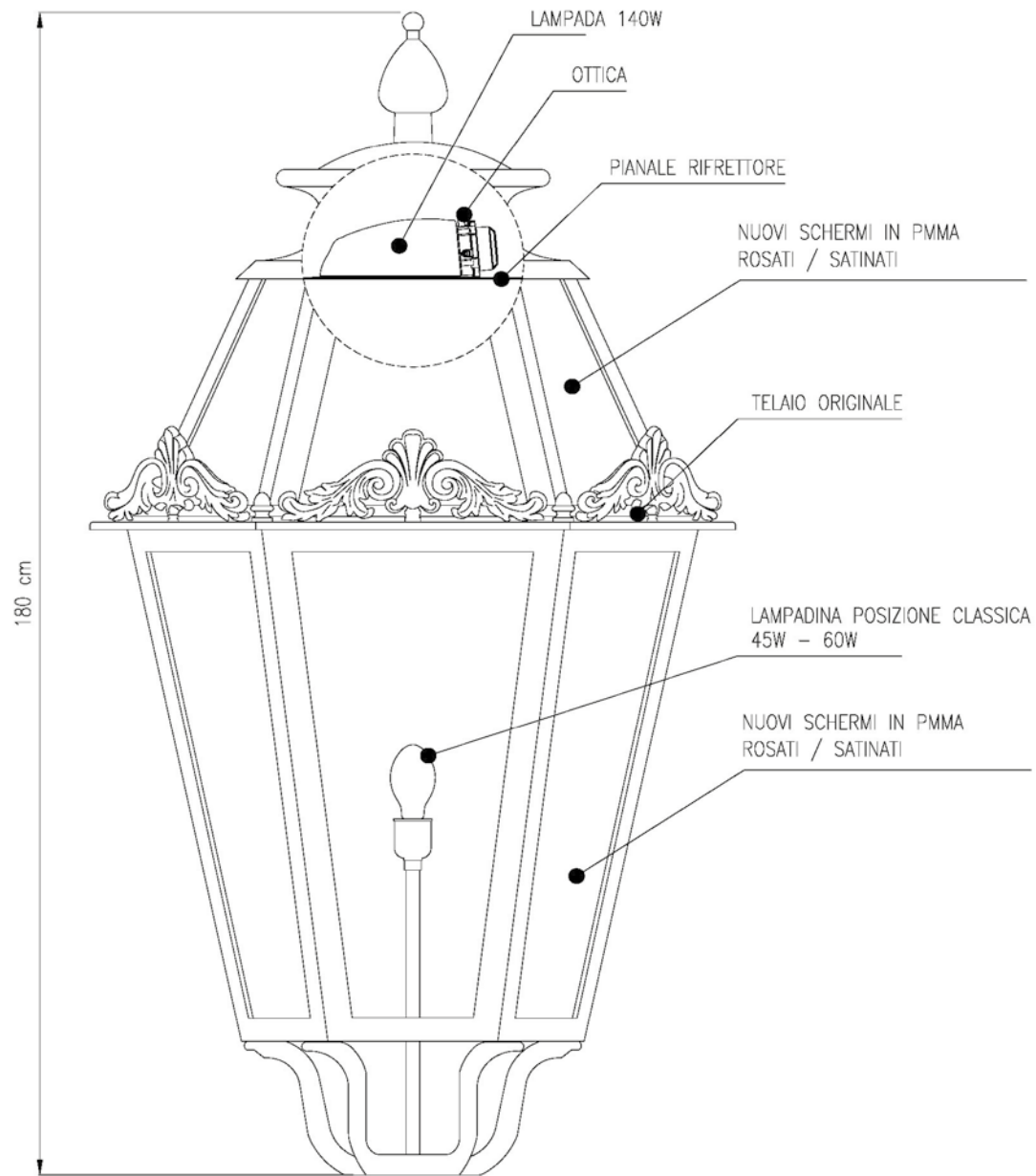

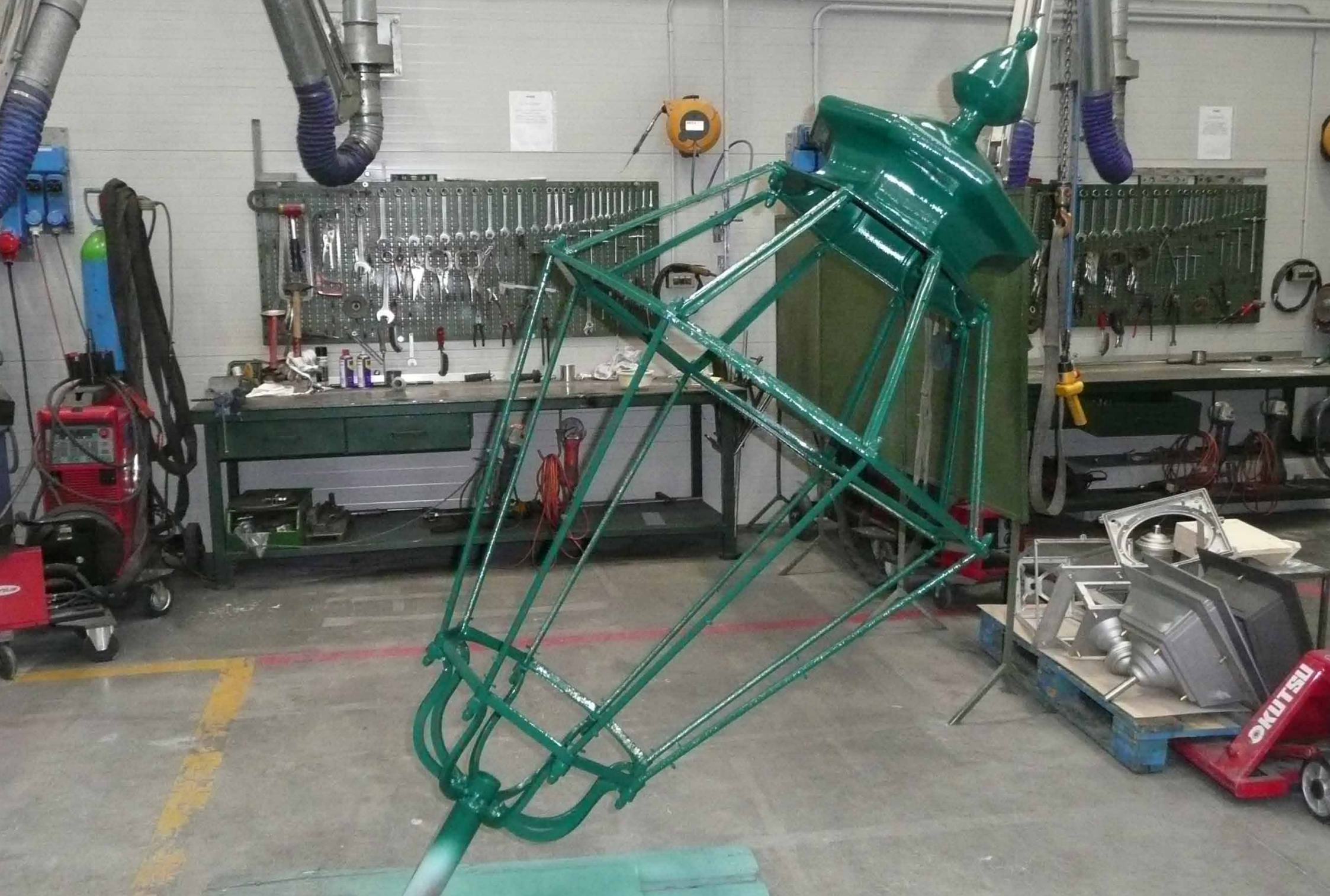







NERI



Venice (Italy) | Punta della Dogana | Lamp post restoration

The day of its assembly finally arrived, and the post has returned to its original position after many years.

Finalmente è giunto il giorno del montaggio e il palo ritorna dopo anni al suo posto originale.

<https://www.youtube.com/watch?v=Sf3WWZRTTDk>









The result is outstanding, and much appreciated by citizens and, naturally, tourists, as a perfect place for a photograph against the backdrop of Palazzo Ducale of the San Giorgio Island.

Il risultato è stato ottimo e molto apprezzato sia dai cittadini che dai turisti; un punto privilegiato per fotografarsi con lo sfondo del Palazzo Ducale o dell'isola di San Giorgio.















fundamentals biennale architettura 2014 7.06-23.11

















CREDITS

Photographs © Antonio Neri, Neri SpA

Photograph P.3 © Givaga

Photograph P.4 © DaLiu

Photograph P.5 © Syriopro

Photograph P.7 © Perseomed

Photograph P.8 © paulprescott72

Historical photos © Fondazione Neri – Italian Museum of Cast Iron

CREDITI

Fotografie © Antonio Neri, Neri SpA

Fotografia P.3 © Givaga

Fotografia P.4 © DaLiu

Fotografia P.5 © Syriopro

Fotografia P.7 © Perseomed

Fotografia P.8 © paulprescott72

Foto storiche © Fondazione Neri – Museo Italiano della Ghisa

Thank you

Grazie